



DANSKE STATSBANER
GENERALDIREKTORATET

VEJLEDNING I KENDSKAB
TIL
VOGNMATERIELLET

TEGNINGER

Februar 1957



DANSKE STATSBANER
GENERALDIREKTORATET

VEJLEDNING I KENDSKAB

TIL

VOGNMATERIELLET

TEGNINGER

Februar 1957

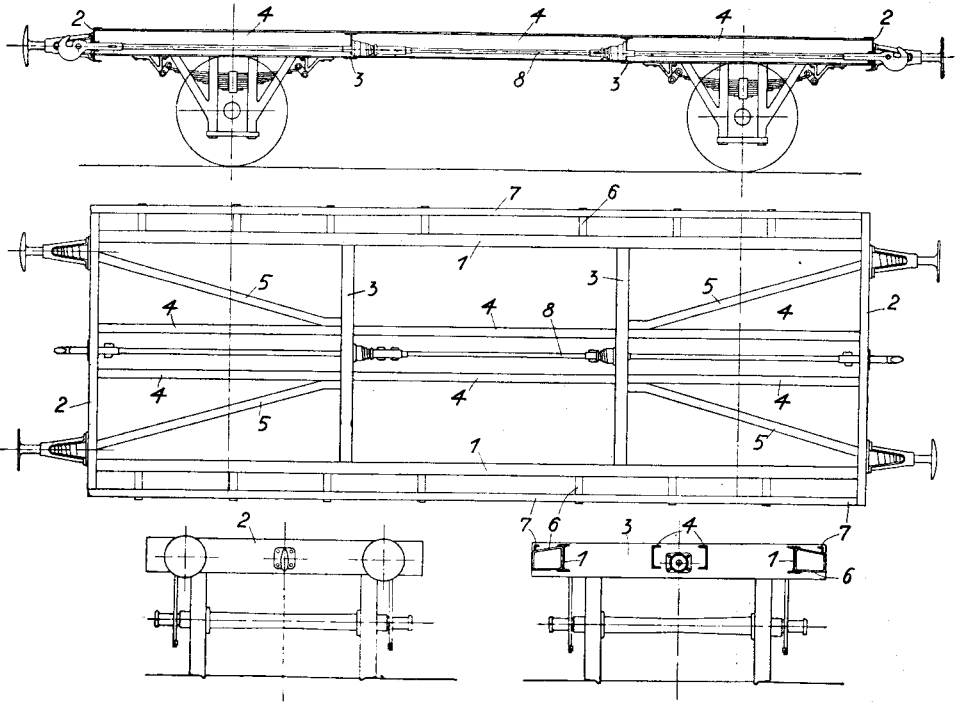

Fig. 1.

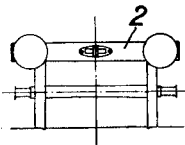
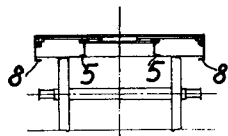
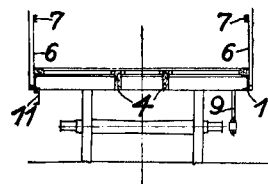
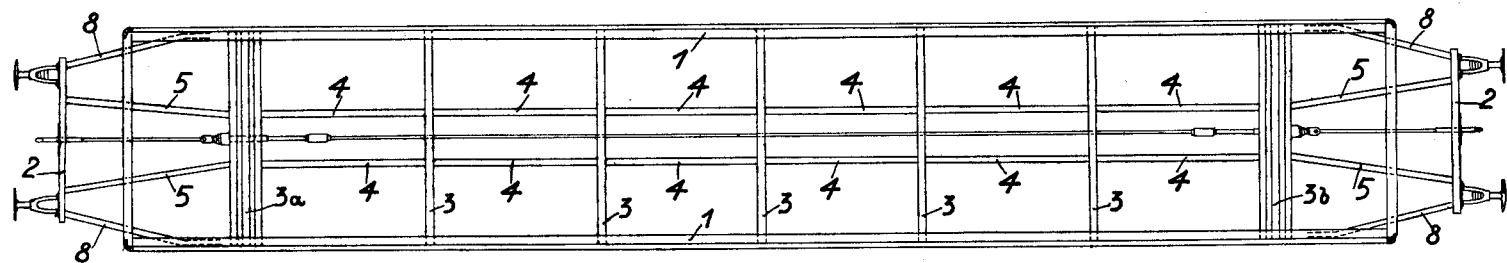
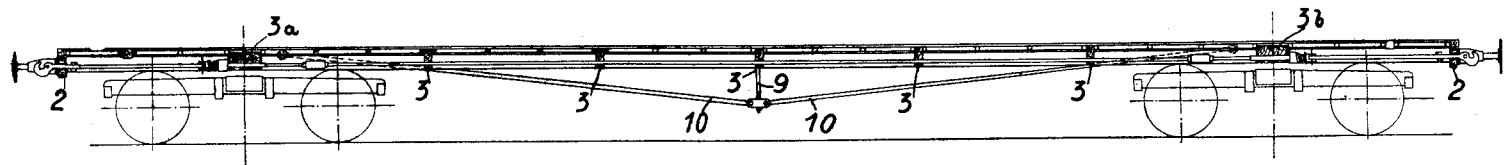

Fig. 2.

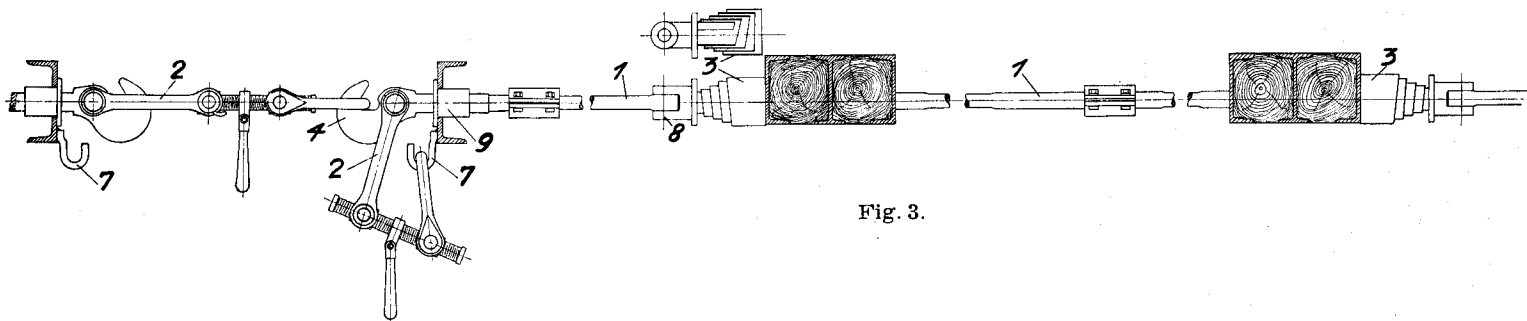

Fig. 3.

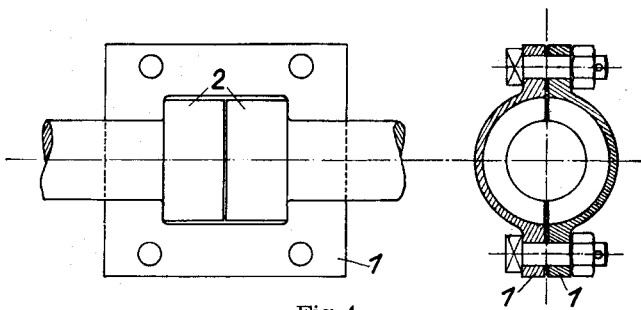

Fig. 4.

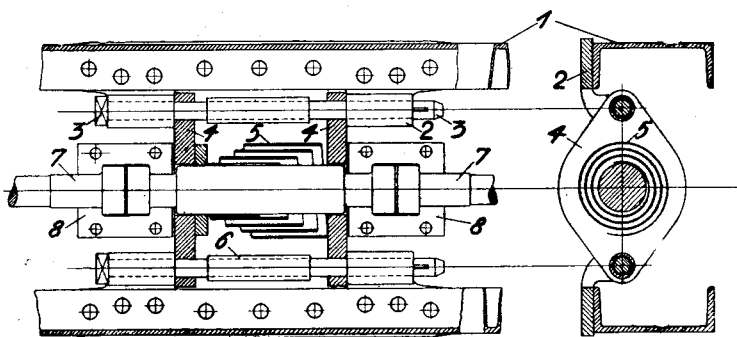

Fig. 5.

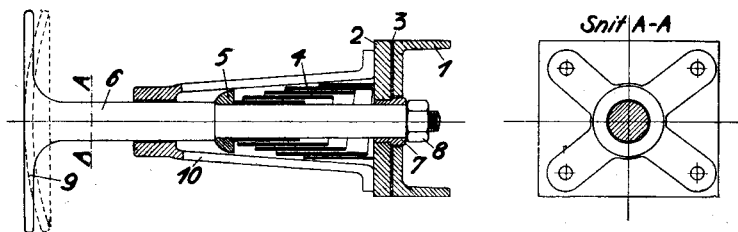

Fig. 6.

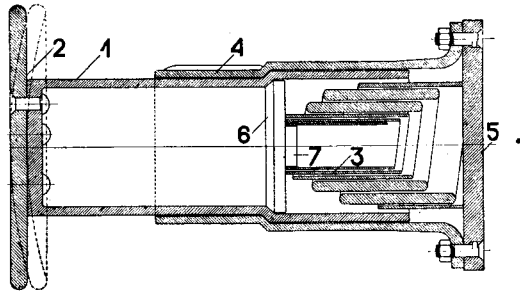

Fig. 7.

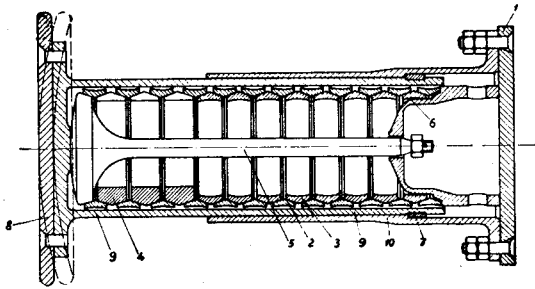

Fig. 8.

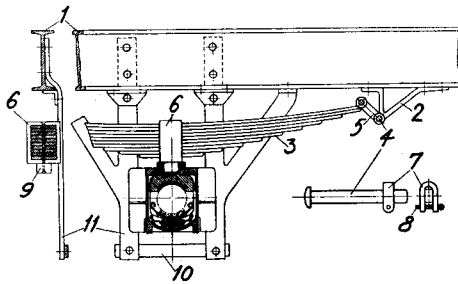

Fig. 9.

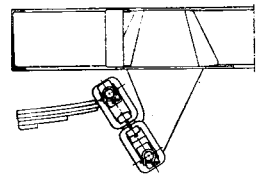

Fig. 10.

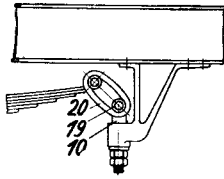

Fig. 11.

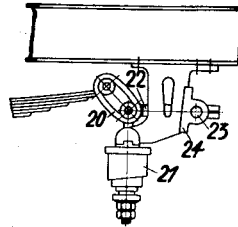

Fig. 12.

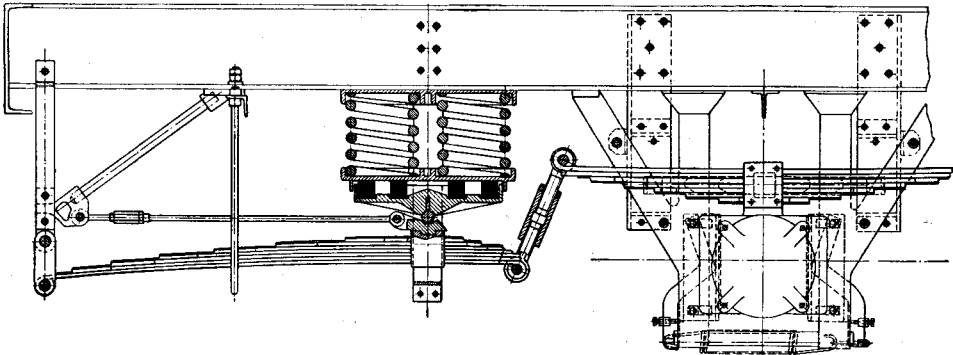

Fig. 13.

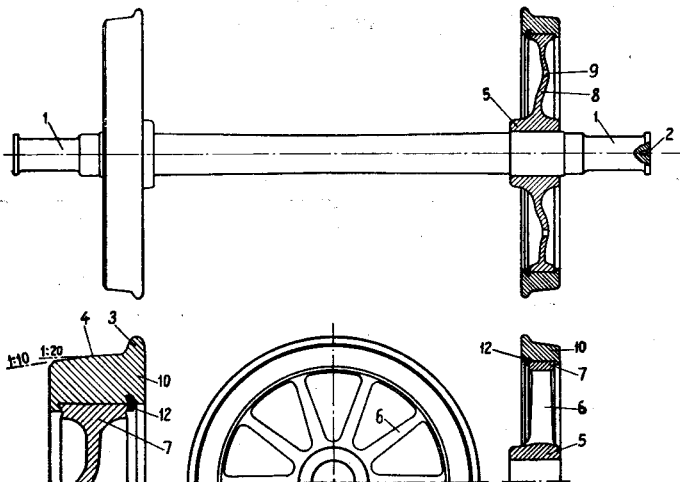

Fig. 14.

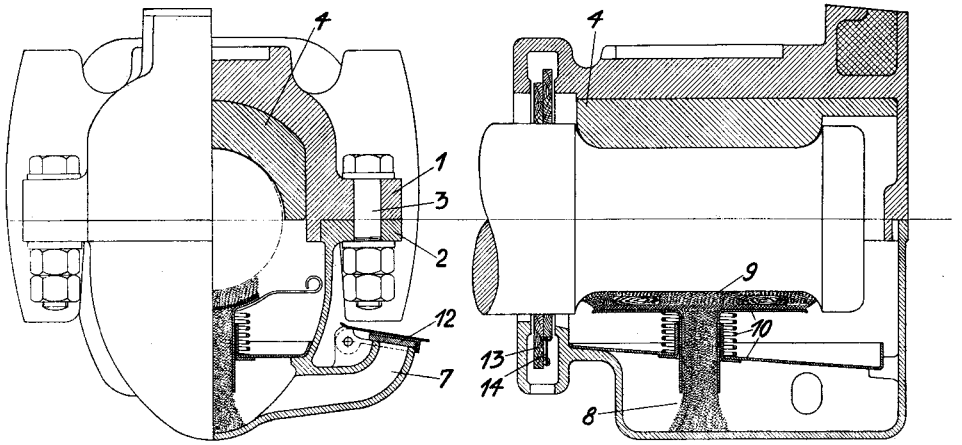

Fig. 15.

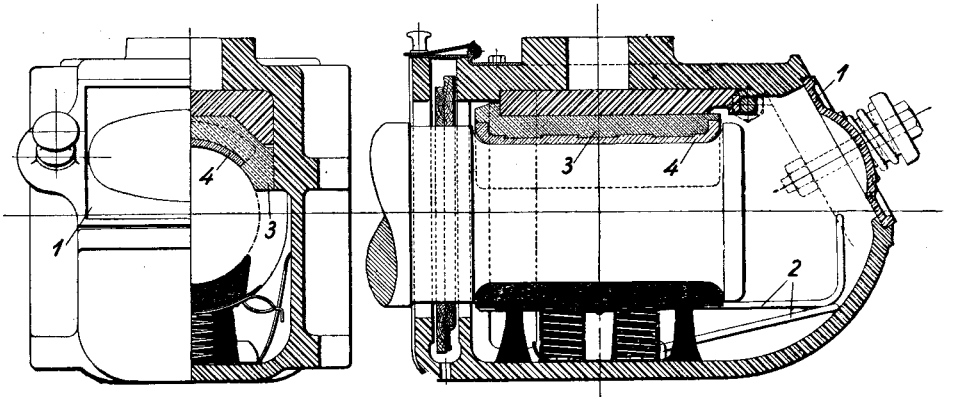

Fig. 16.

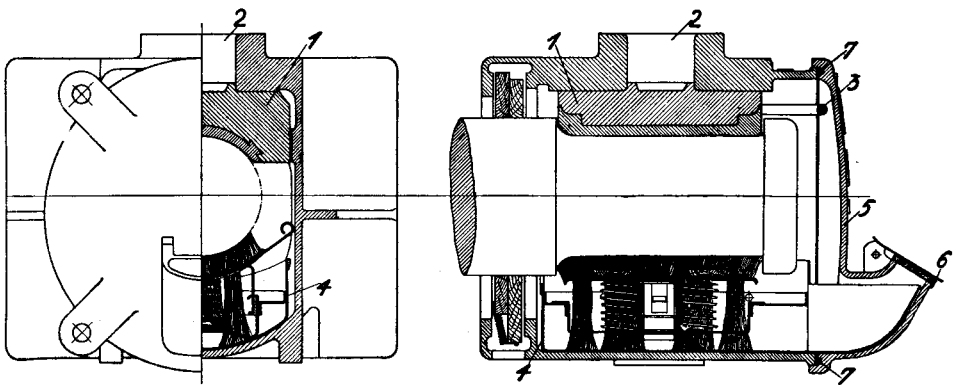

Fig. 17.

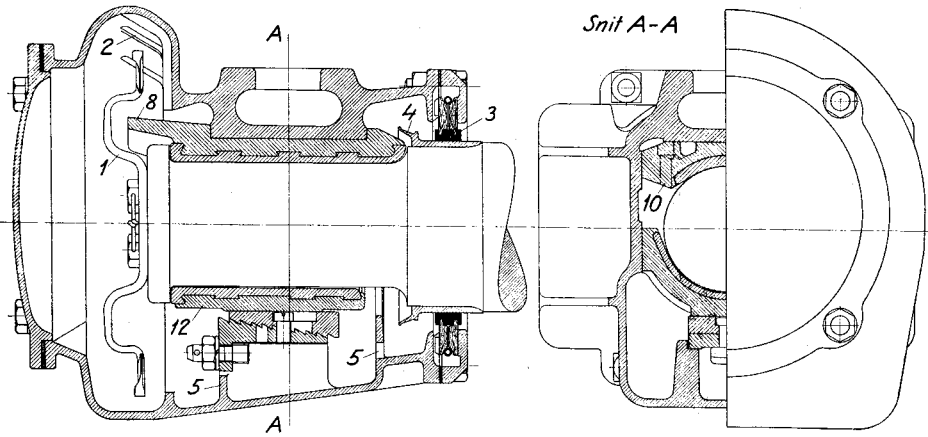

Fig. 18.

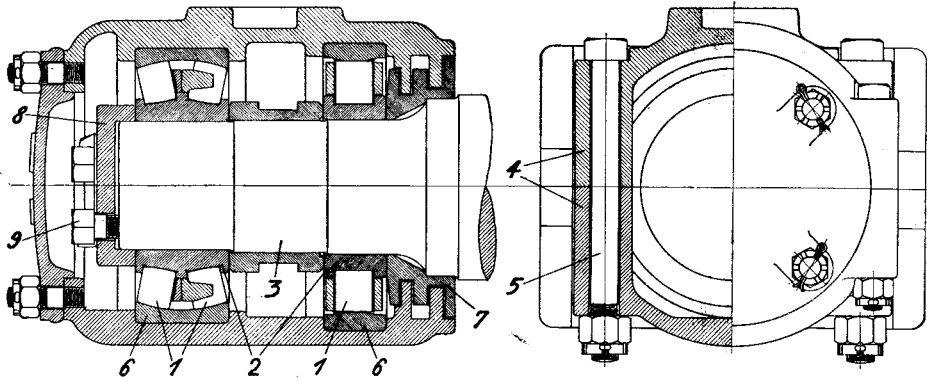

Fig. 19.

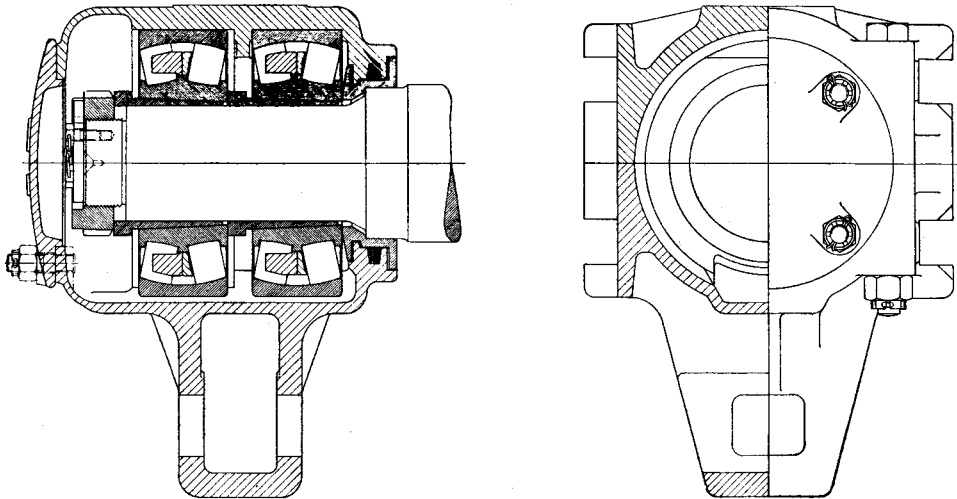

Fig. 20.

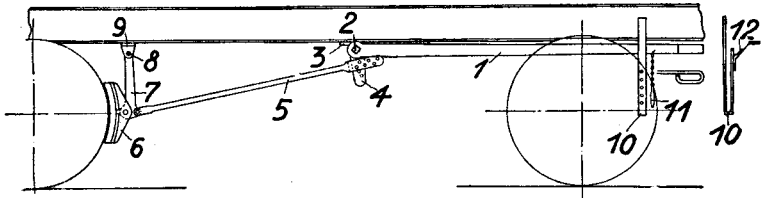

Fig. 21.

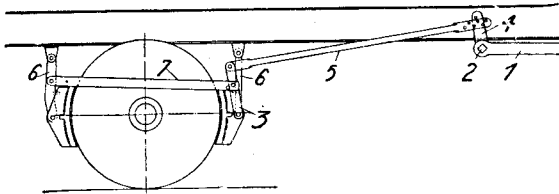

Fig. 22.

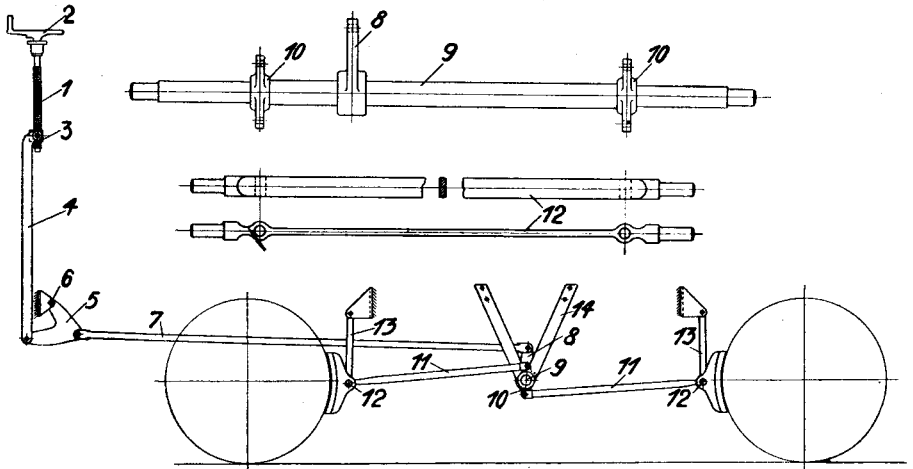

Fig. 23.

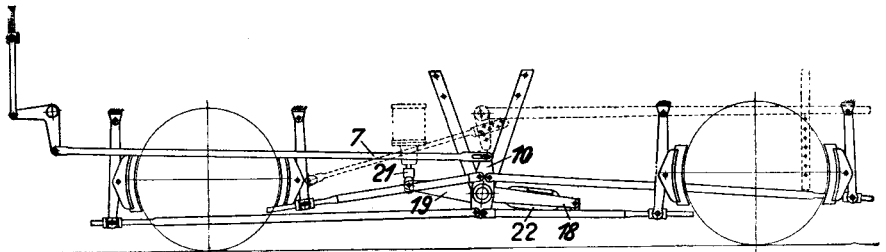

Fig. 24.

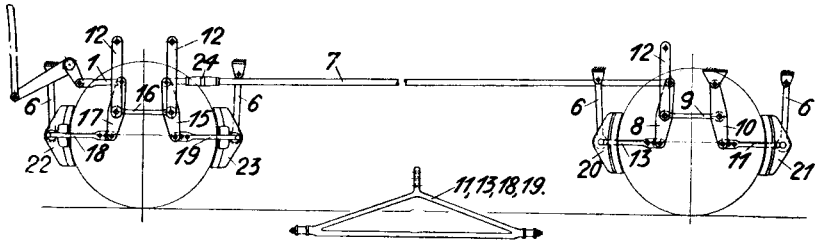

Fig. 25.

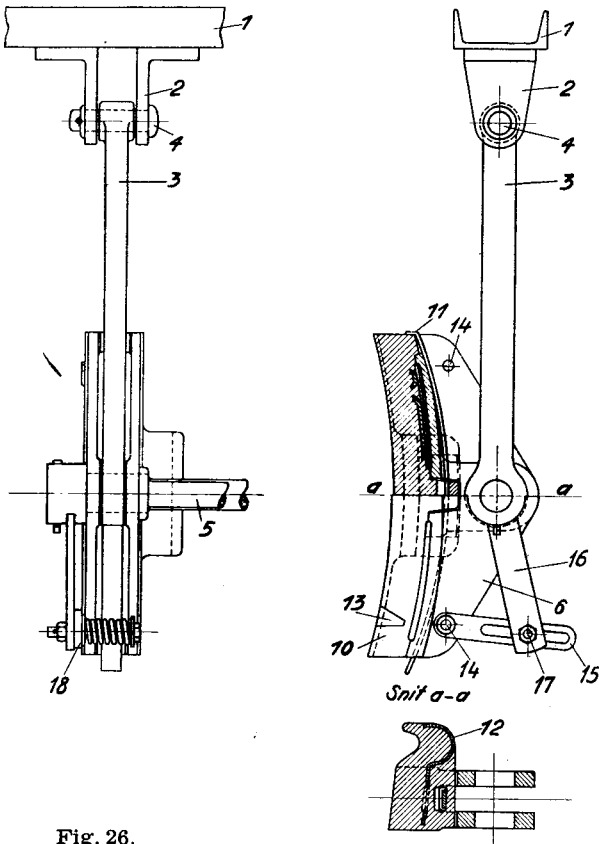
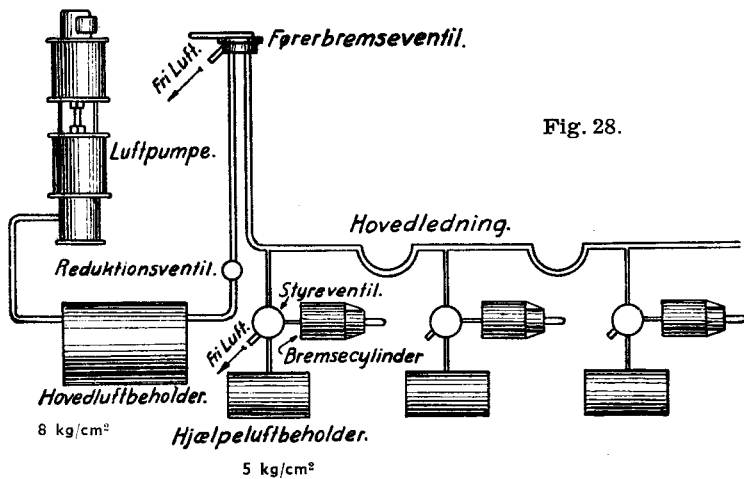
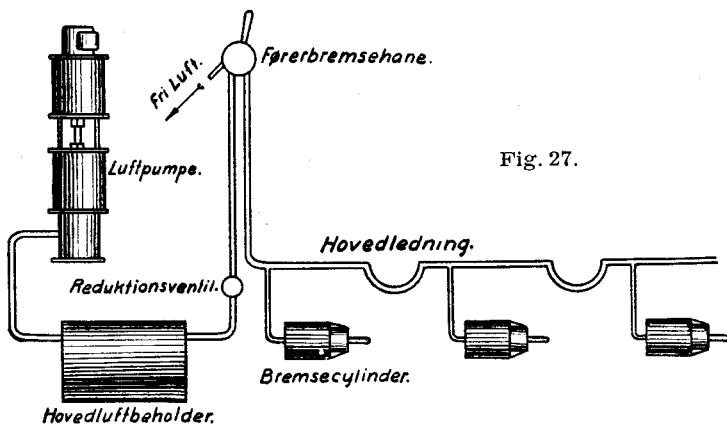
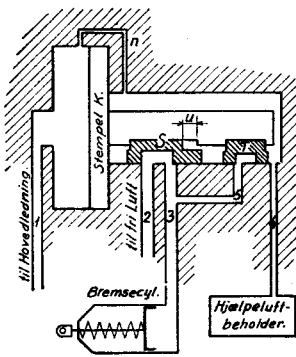

Fig. 26.





a. Fylde- og Løsestilling.

Fig. 29.

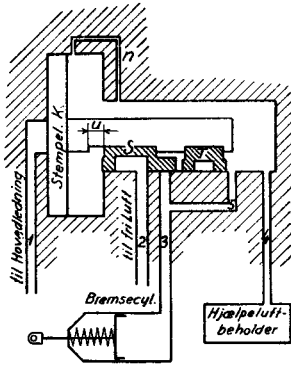

b. Bremsestilling.

Fig. 30.

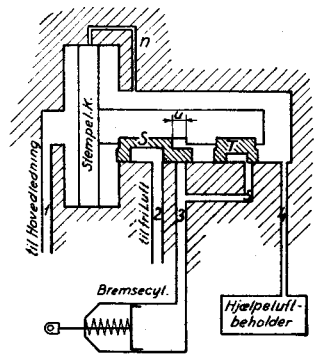

c. Bremseafslutningsstilling.

Fig. 31.

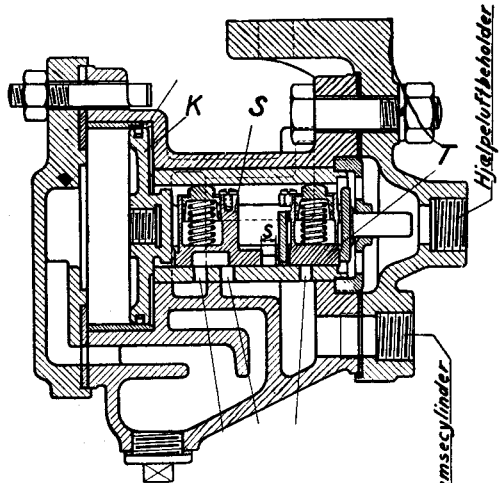
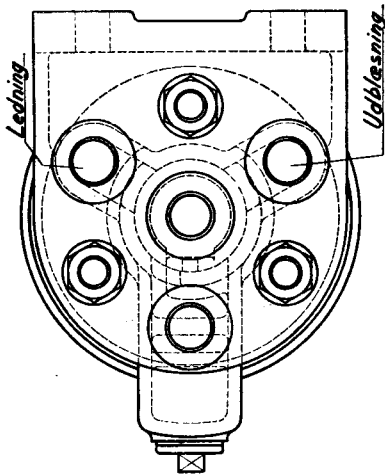
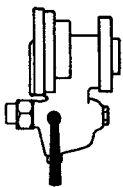
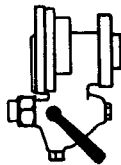

Fig. 32.



Stilling I.



Stilling II.

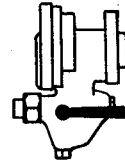

Stilling III.

Fig. 33.

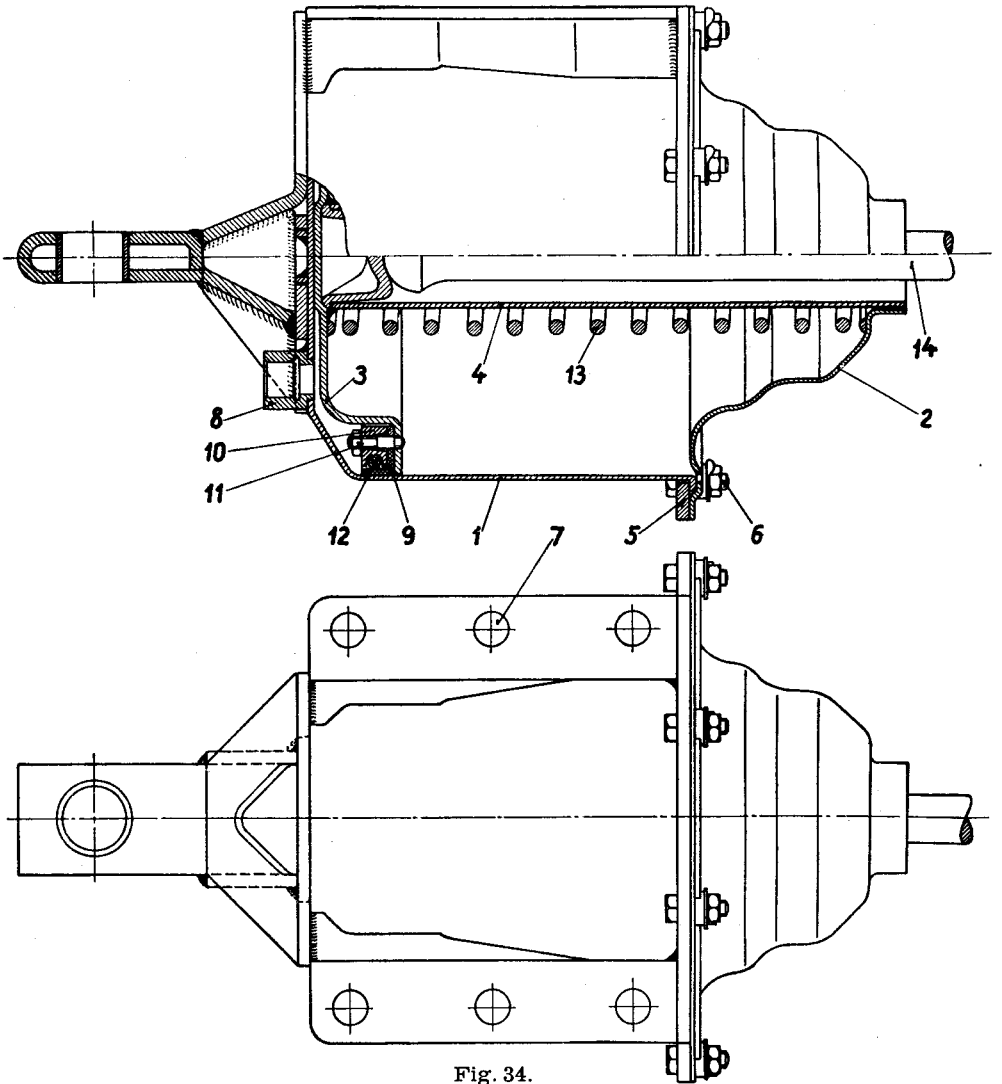
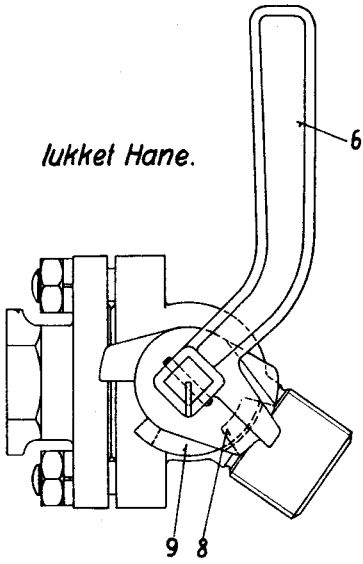

Fig. 34.

lukket Hane.



aaften Hane

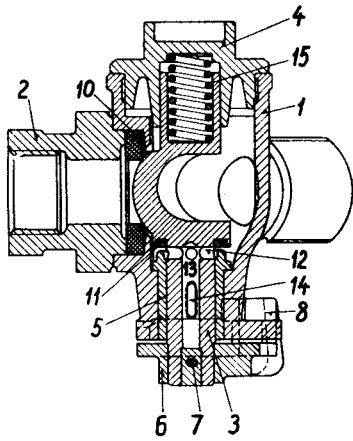
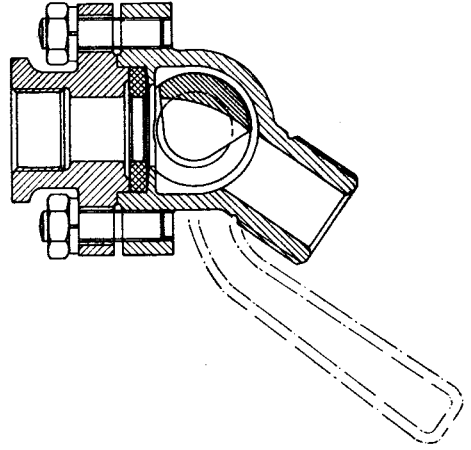

Fig. 35.

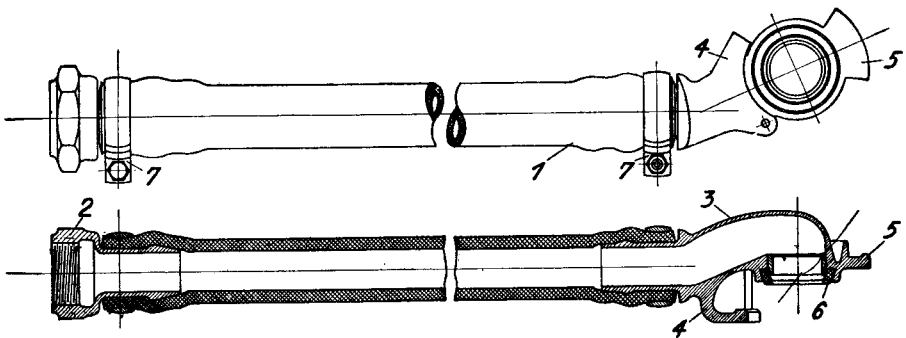

Fig. 36.

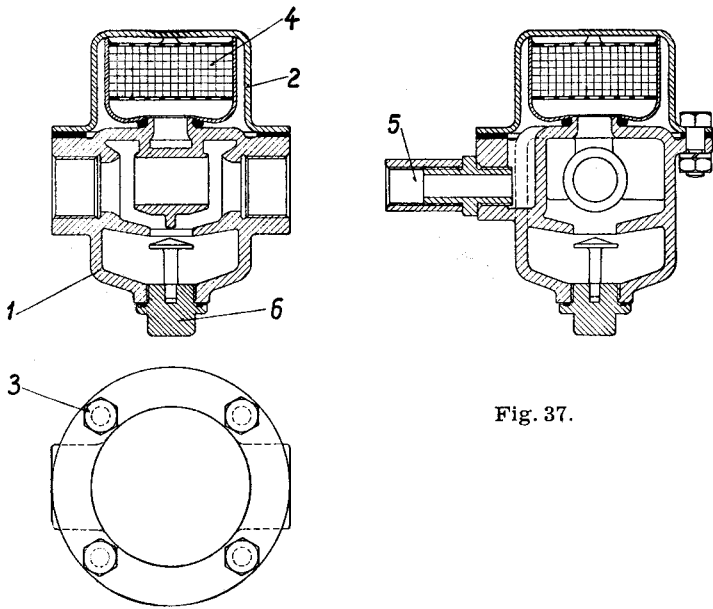

Fig. 37.

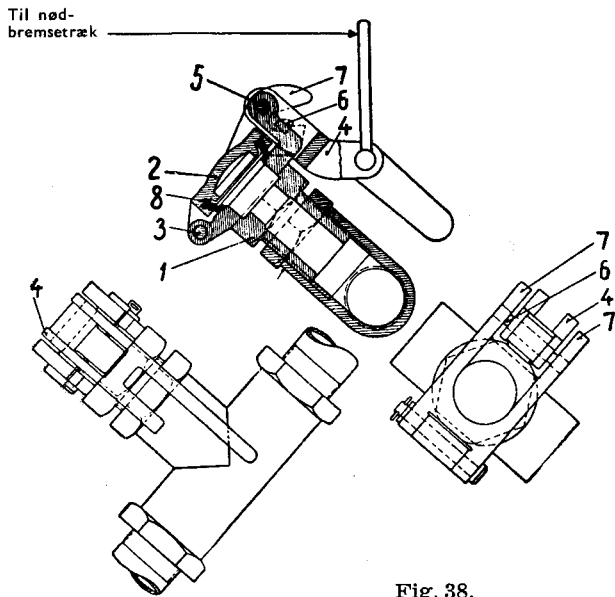
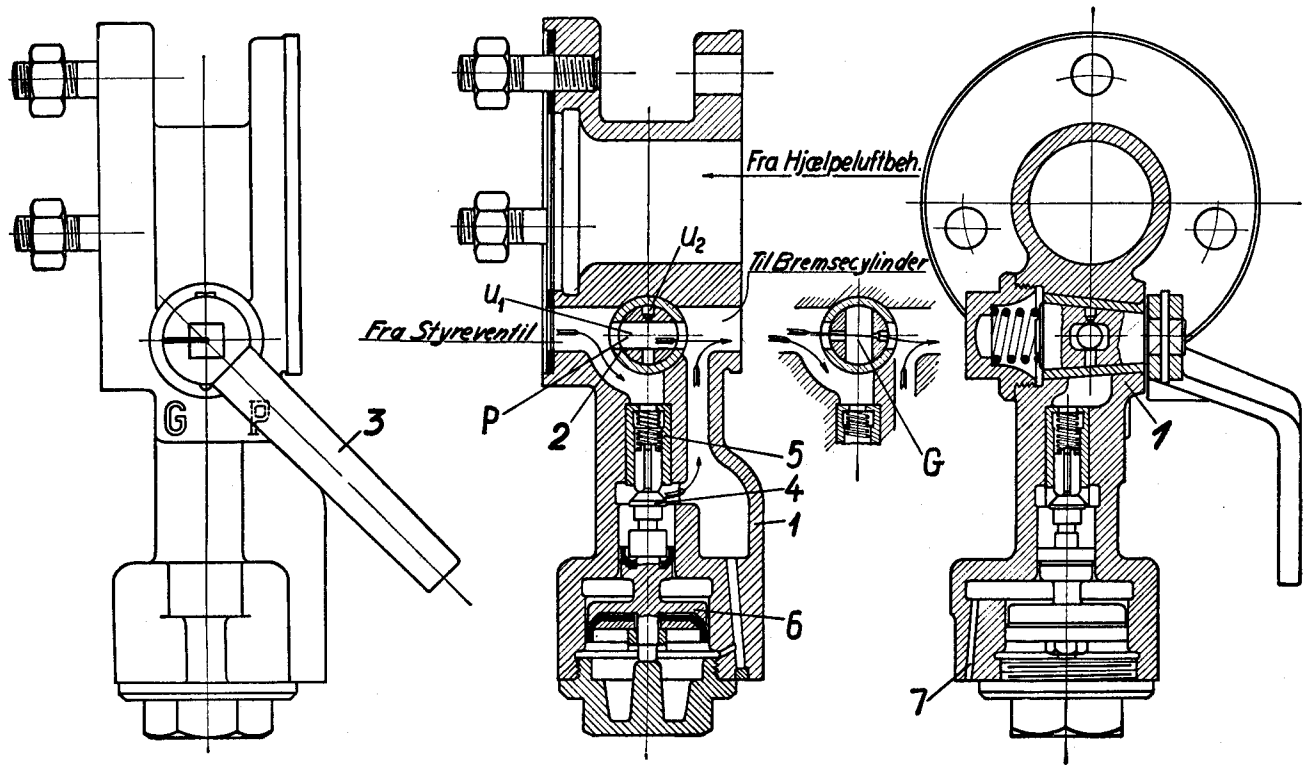

Fig. 38.

Fig. 39.



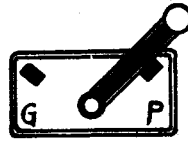
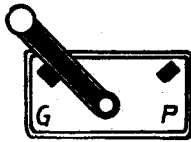

Fig. 40.

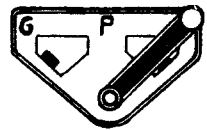
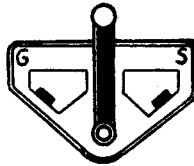
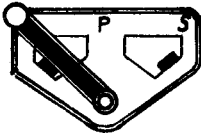

Fig. 41.

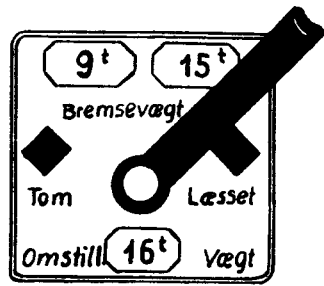
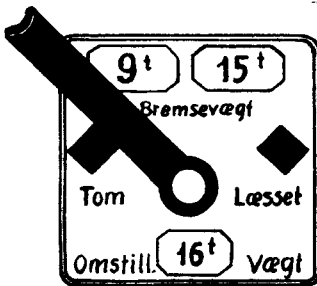

Fig. 42.

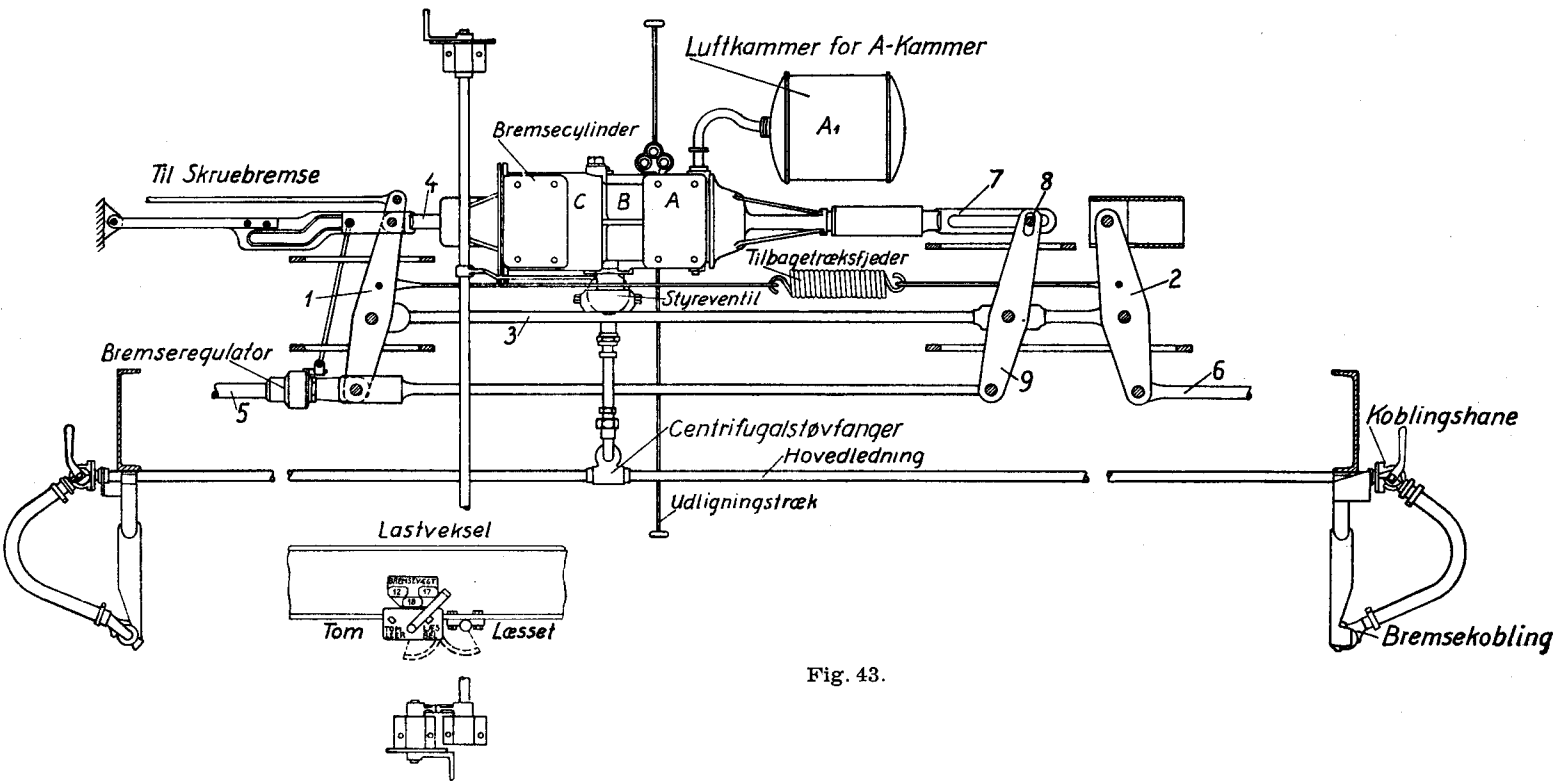

Fig. 43.

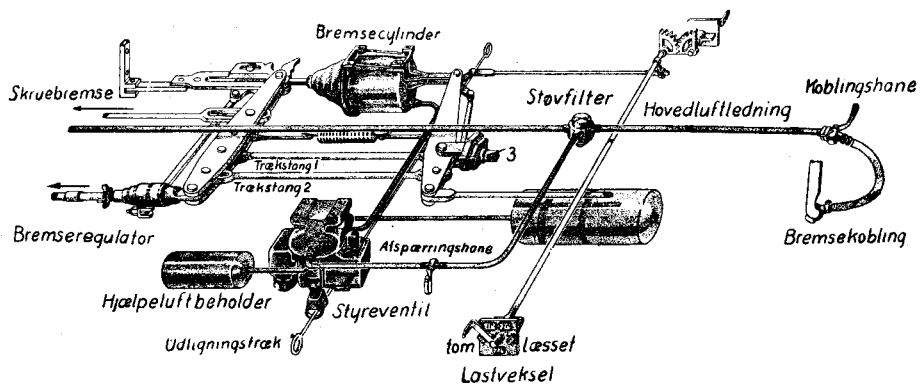

Fig. 44.

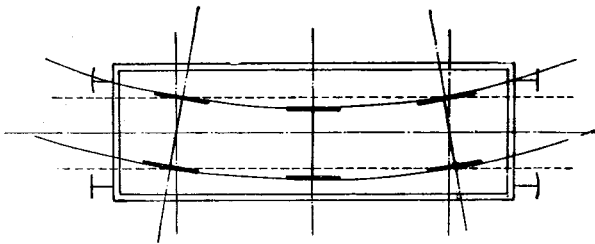

Fig. 45.

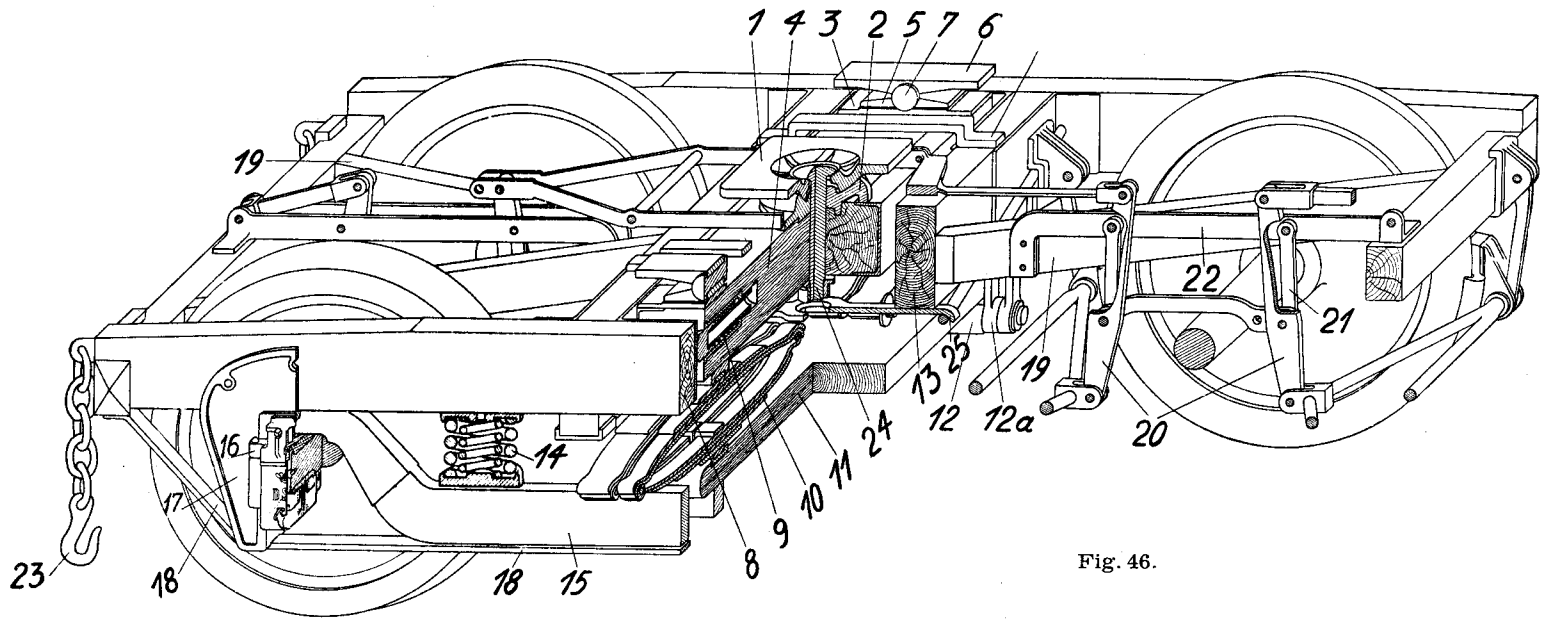

Fig. 46.

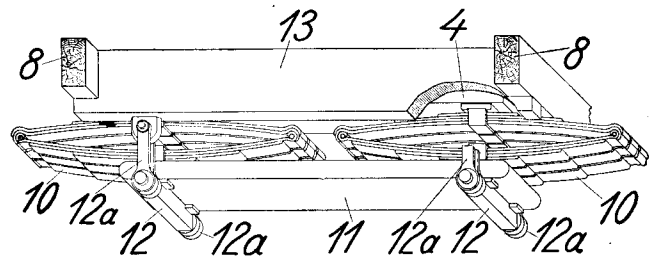

Fig. 47.

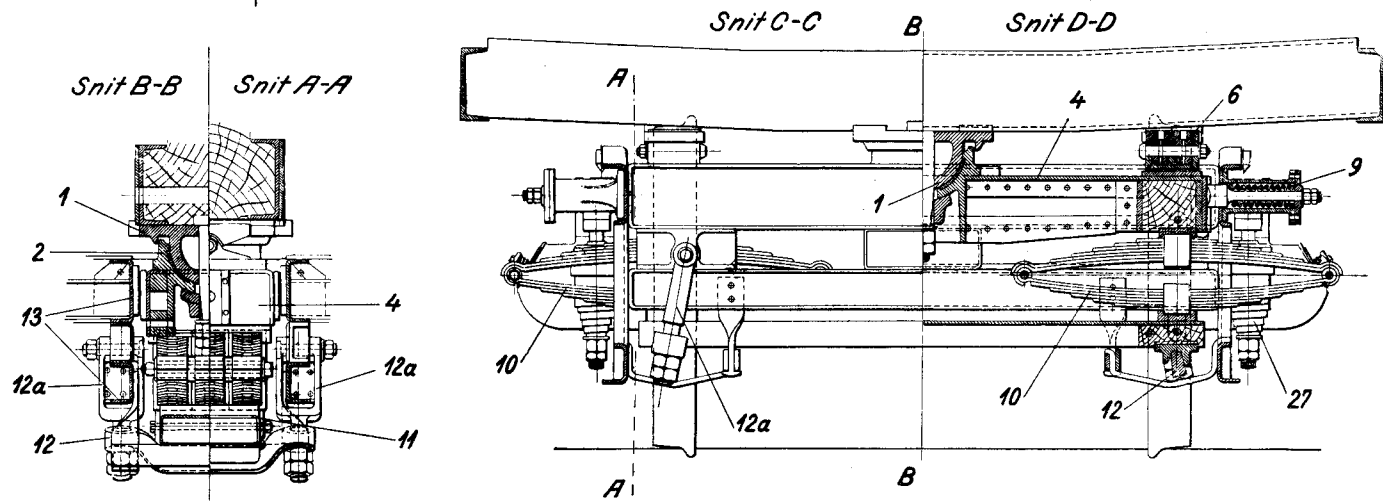
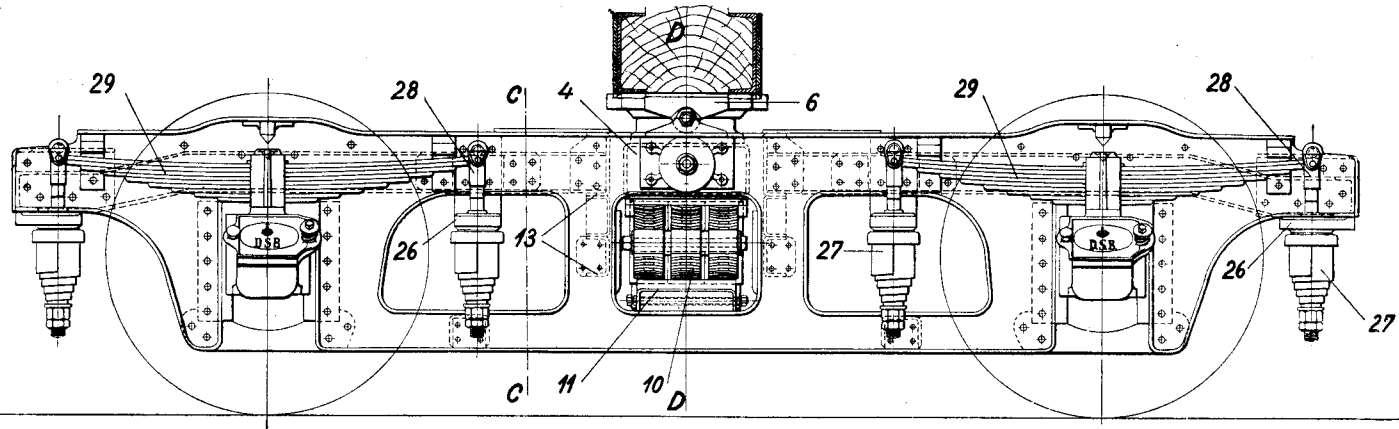

Fig. 48.

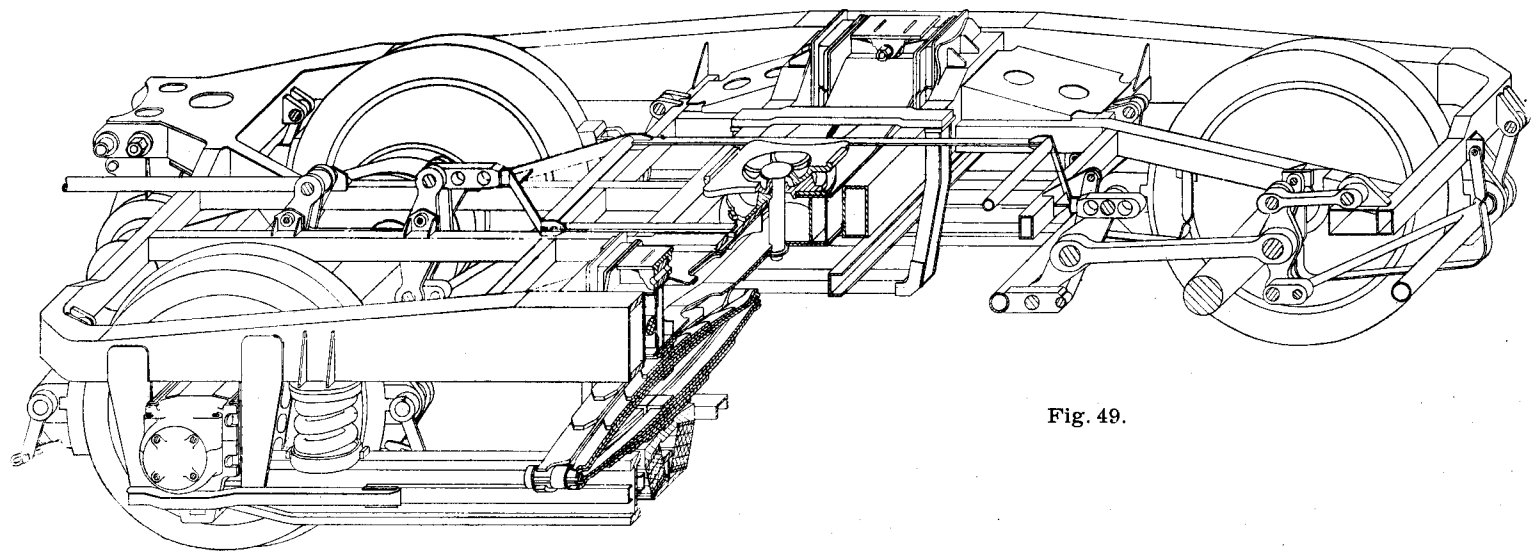

Fig. 49.

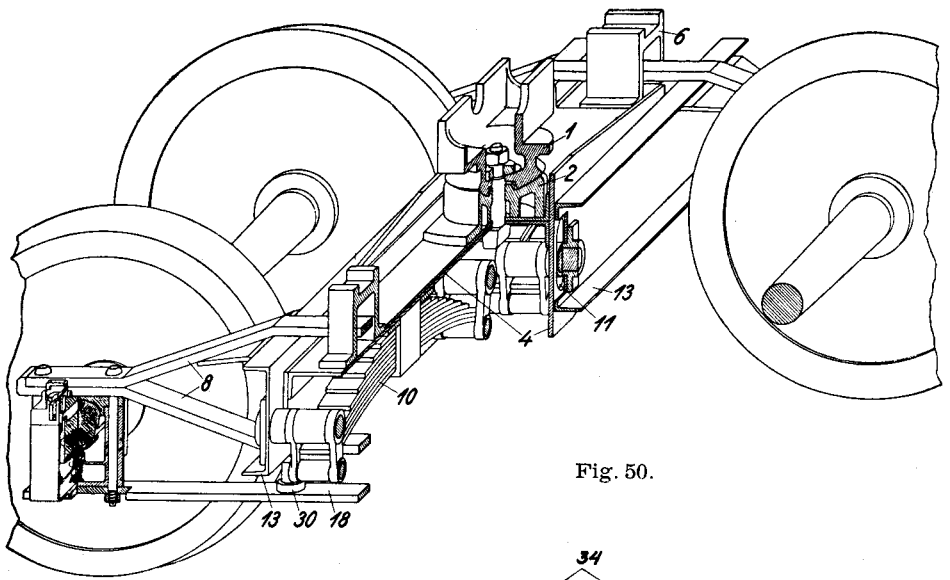

Fig. 50.

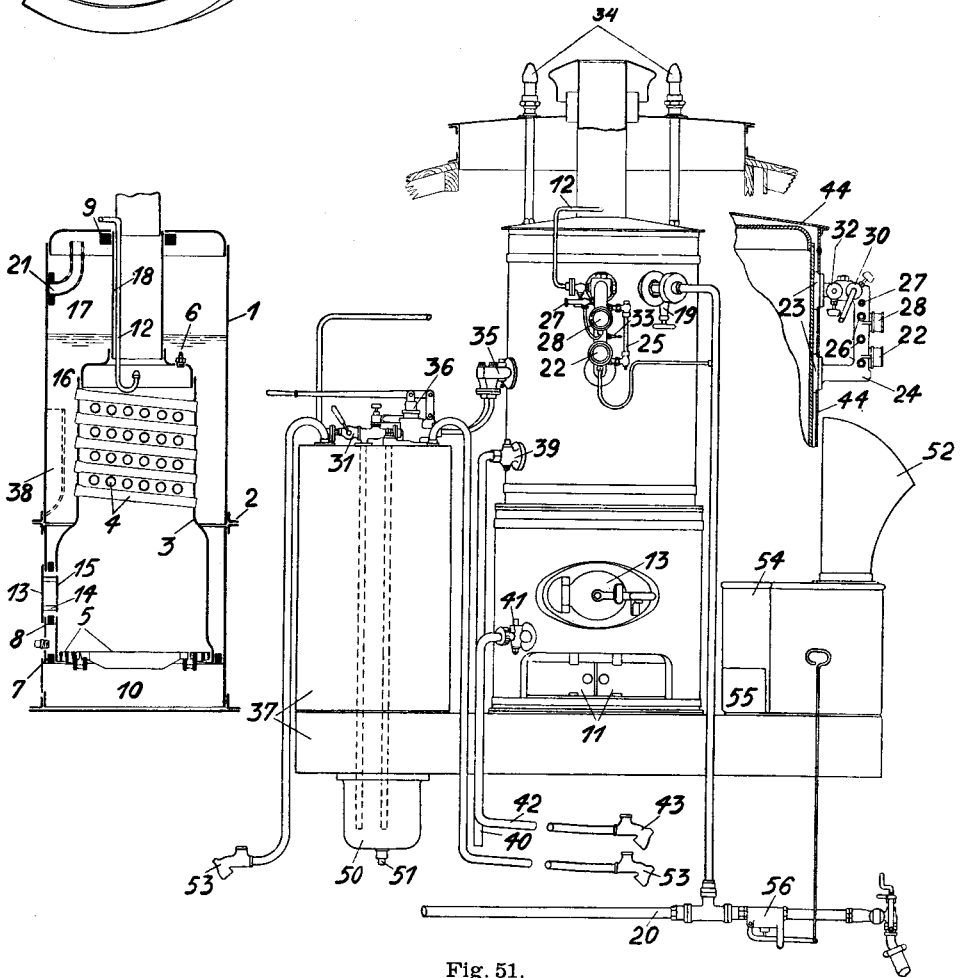

Fig. 51.

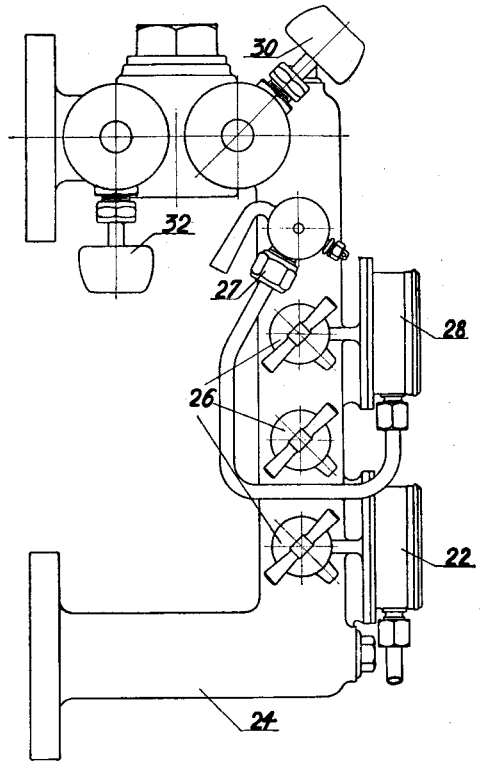
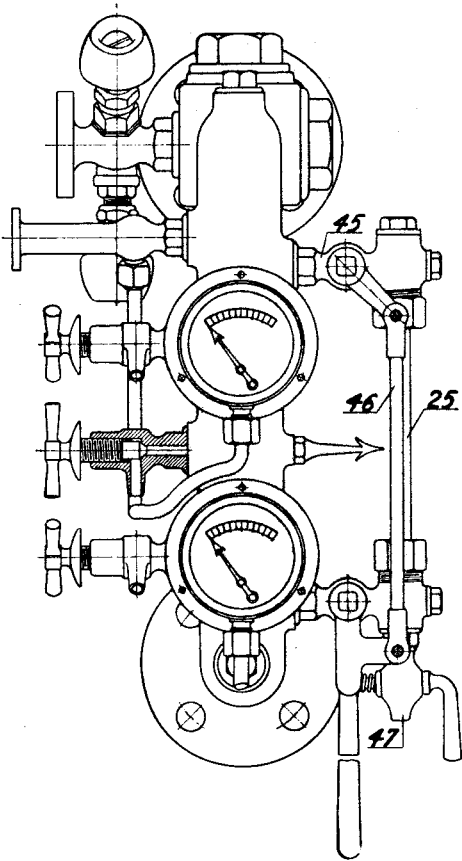
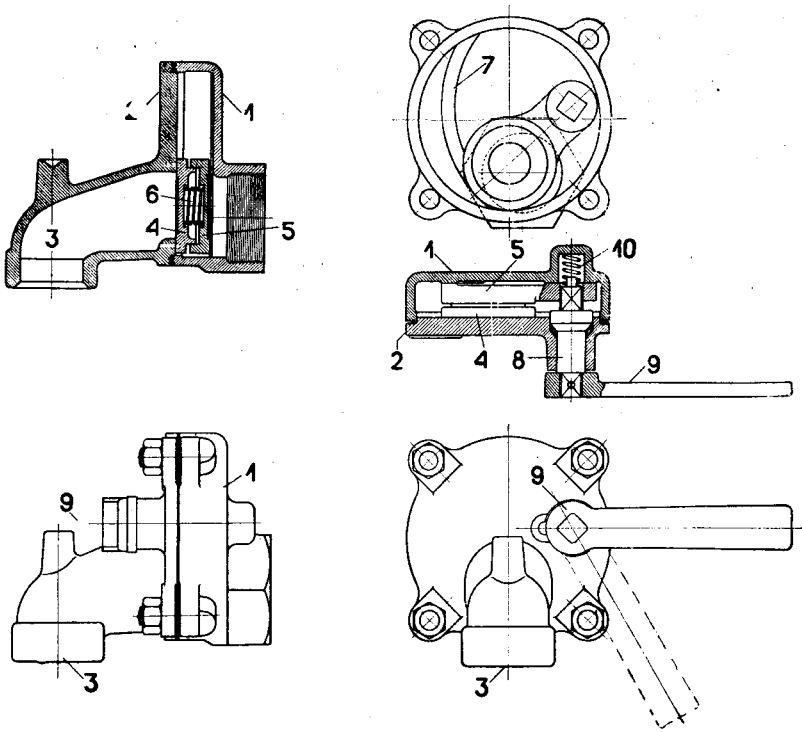
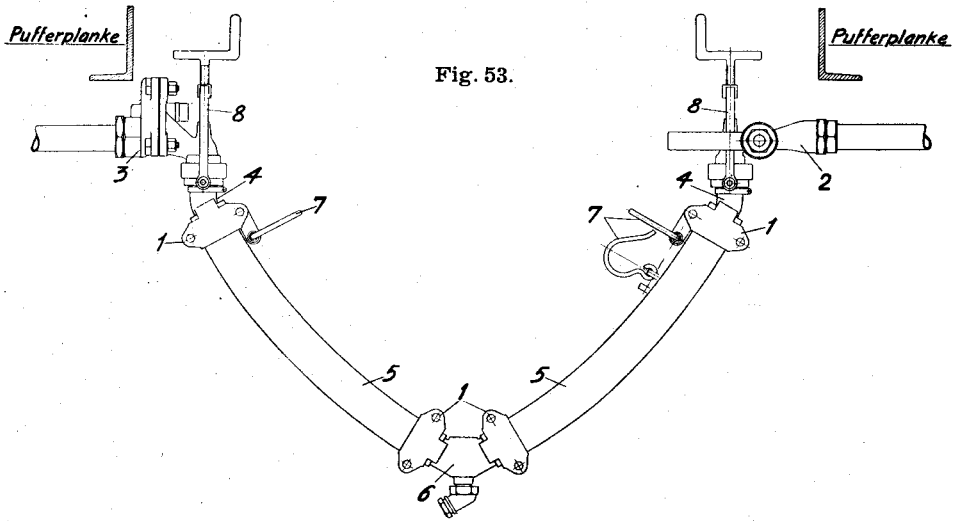

Fig. 52.



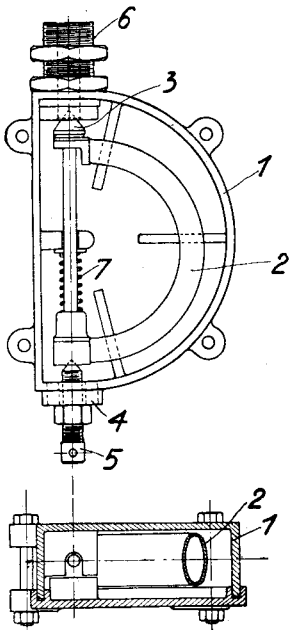

Fig. 55.

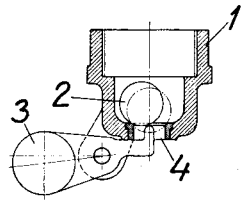

Fig. 56.

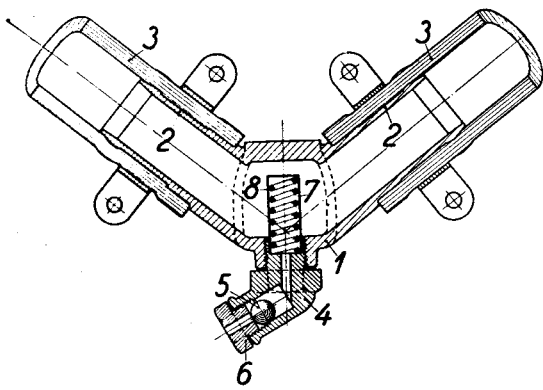

Fig. 57.

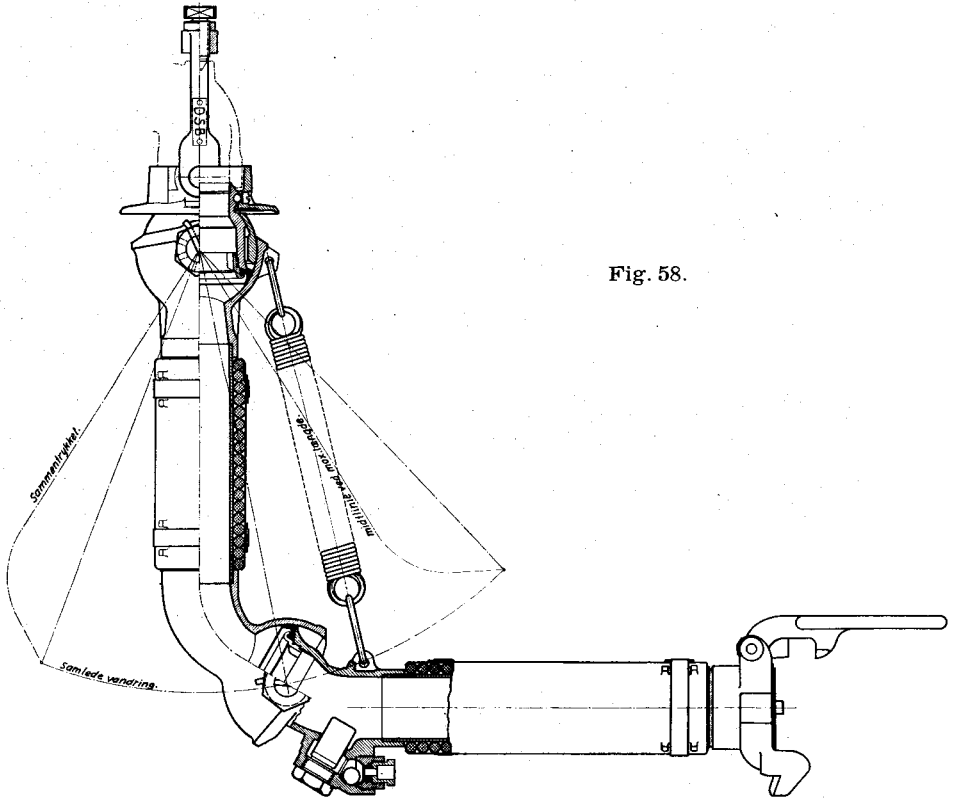

Fig. 58.

